

3000mm dia. Ocean Buoy

ATLANTIC-3000



The ATLANTIC-3000 is a 3m diameter navigation buoy designed for offshore port and coastal applications and offers significant advantages over steel or hybrid designs.

Innovative Modular Design

The ATLANTIC-3000 is the only buoy in its class to offer a large 3m diameter float section without the incorporation of a central mooring post.

The float section of the ATLANTIC-3000 is built from a large central chamber with a ring of float collars*.

This design offers several benefits including;

- Fast, safe and easy to assemble
- Lightweight – up to 60% lighter than competitor models
- Replaceable exterior sections in the event of impact damage
- Multiple buoyancy chambers to provide a higher level of redundancy
- Ability to interchange colours to provide striped combinations such as IALA safe water or wreck marks.

10 Tonne Safe Working Load

Large, integrated lifting and mooring eyes offer a safe working load of up to 10T (2-eye lift) which is comparable to traditional steel designs. This is achieved by an innovative strengthened internal bracing design that connects these lifting and mooring points*.

Easy to assemble, deploy and service

When compared to other 3m navigation buoys, the ATLANTIC is easier to assemble, deploy and service. The buoy can be easily manoeuvred around site by convenient forklift access points, is lightweight and can sit flat on the deck of a vessel.

The ATLANTIC-3000 can be supplied in all IALA colours, and can carry a significant payload including power supplies, met hydro and telemetry equipment.

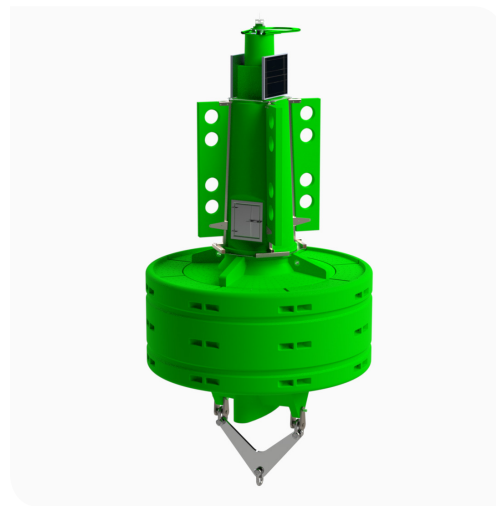
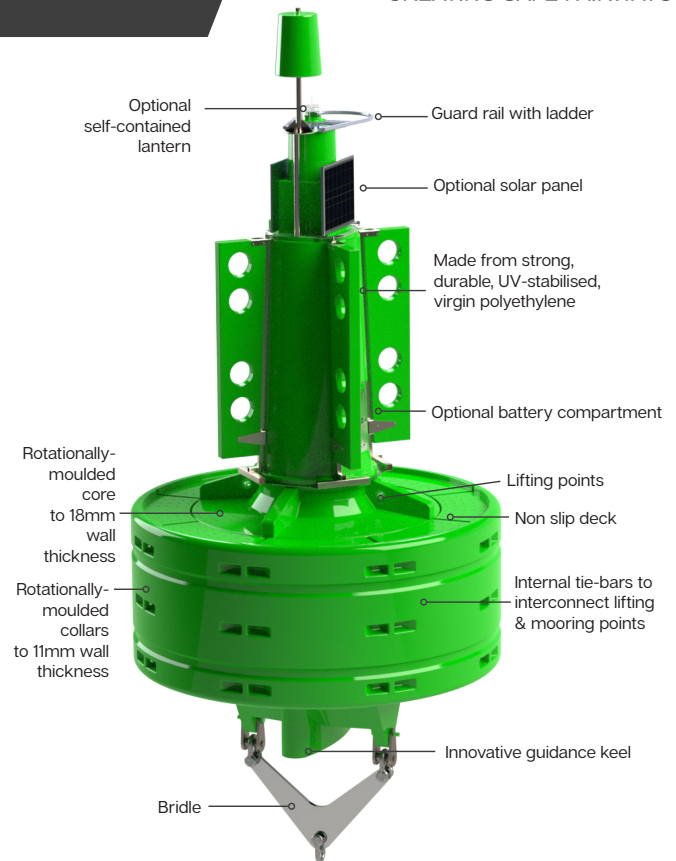

The Sealite Advantage

- High visibility red, green, white or yellow as per IALA recommendations
- All polyethylene design
- Lower assembly costs than traditional steel/plastic hybrid buoys
- Lightweight
- 316-grade stainless steel, moulded-in tie bars provide outstanding lifting strength
- Easy shipping, assembly, and on-station servicing
- Easy to deploy and service
- No painting, ever
- Cost effective & environmentally friendly

Technical Specifications*

ATLANTIC-3000	
General Characteristics	
Available Colours	Red, Green, White, Yellow as per IALA Recommendations
Focal Plane Height (mm/inches)	4350 / 171 $\frac{3}{4}$
Total Float Volume (ltrs/US gallon)	9587 / 2532
Nominal Freeboard (mm/inches)	1095 / 43 $\frac{1}{2}$
Nominal Draft (mm/inches)	845 / 33 $\frac{3}{8}$
Total Buoyancy (kgs/lbs)	8000 / 17636
Reserve Buoyancy (kgs/lbs)	2650 / 5842
Maximum Mooring Load (kgs/lbs)	2650 / 5842
Draft, Maximum (mm/inches)	1240 / 48 $\frac{3}{8}$
Freeboard, Minimum (mm/inches)	700 / 27 $\frac{1}{2}$
Safe Working Load, 1pt (kgs/lbs)	5000 / 11023
Safe Working Load, 2pt (kgs/lbs)	10000 / 22046
Submergence (kg/cm, lb/inches)	63 / 352 $\frac{3}{8}$
Visual Area (m ² /ft ²)	5.9 / 63 $\frac{1}{2}$ 7.2 / 77 $\frac{1}{2}$ (with day marks)
Water Area (m ² /ft ²)	1.3 / 14
Physical Characteristics	
Material	Rotationally-moulded UV-stabilised virgin polyethylene, 316-grade internal tie bars, lifting & mooring eyes
Wall Thickness (mm/inches)	18 / 0.70(core) 11 / 0.43 (collars)
Ballast (kg/lbs)	500 / 1102 internal concrete
Filling	Closed-cell polyurethane foam (float section)
Radar Reflector	Echomax
Height (mm/inches)	ATLANTIC-3000 Standard Model: 6010 / 236.6
Width (mm/inches)	3000 / 118 $\frac{1}{2}$
Mass (kg/lbs)	1825 / 4024
Product Life Expectancy	>20 years
Certifications	
IALA	Surface colours compliant to IALA E-108
Quality Assurance	ISO 9001:2015
Intellectual Property	
Trademarks	SEALITE® is a registered trademark of Sealite Pty Ltd
Warranty*	
	5 years
Lantern Options	
	Sealite SL-75, SL-C310, SL-C410, SL-C415, SL-C420, SL-125 Series or SL-155 Series, Racon
Options Available	
	<ul style="list-style-type: none"> • Mould-in graphics • Day marks • Monitoring Systems (AIS, GSM)

Technical Illustrations

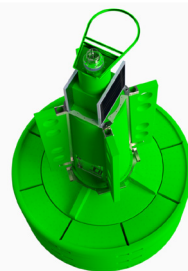
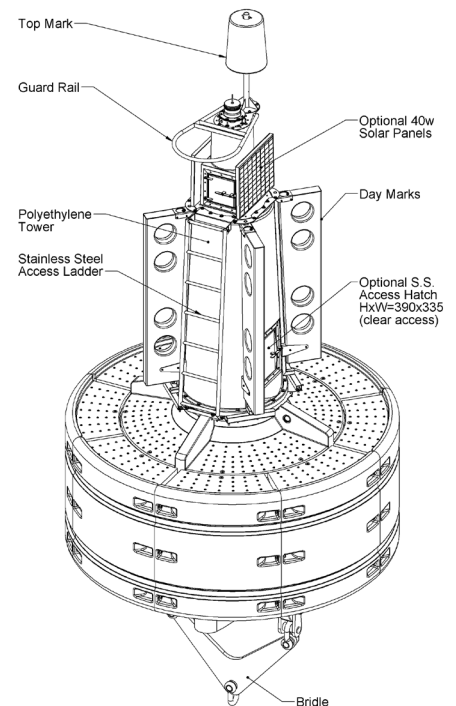
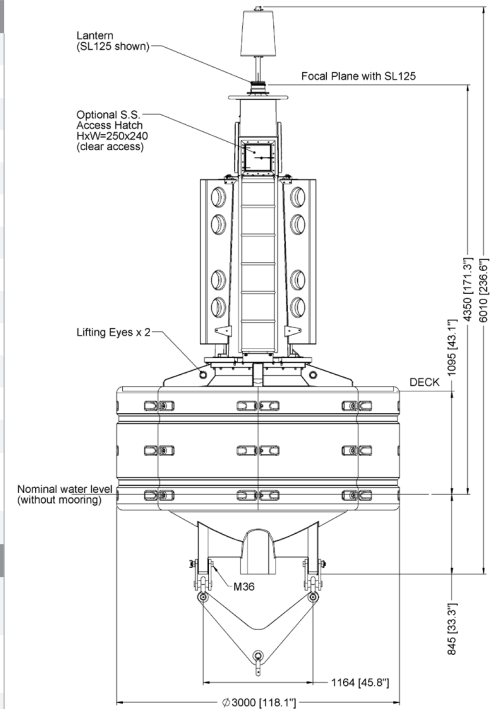

We believe technology improves navigation™

